

PROMAX NEWSLETTER

16 / 2008



TV EXPLORER ✓

Satellite Hunter ✓

TV Distribution Systems ✓

COFDM Transmodulators ✓

Transport Stream Recorder & Player ✓

Monitoring Systems for Broadcast ✓

Cable Television ✓

Monitoring Systems for Cable TV ✓



TV EXPLORER

HDTV EXPLORER	3
TV EXPLORER II+ Setting new standards	4
Merogram: MER by carrier as a function of time.....	5
Spectrogram: Spectrum display as a function of time.....	5
The "ECHOES" on the DTT reception.....	6
NetUpdate: Much more than just updating firmware.....	7

SATELLITE HUNTER

SATHUNTER: including DVB-S2 for HD channels.....	8
---	---

TV DISTRIBUTION SYSTEMS

DIGITAL TO TV: Digital from satellite to TV.....	10
---	----

COFDM TRANSMODULATORS

COFDM Transmodulators QPSK to COFDM MO-162 / MO-163	12
COFDM Modulators DVB-T/H MO-160 / MO-161	13

TRANSPORT STREAM RECORDER & PLAYER

Portable DTT Receiver and TS Recorder / Processor / Player TG-130	14
--	----

MONITORING SYSTEMS FOR BROADCAST

Monitoring systems: PROWATCH TELMO	16
---	----

CABLE TELEVISION

Cable TV & data analyser PROMAX-26+	18
--	----

MONITORING SYSTEMS FOR CABLE TV

PROWATCH DEIDE 3 for cable TV headends.....	20
--	----

HDTV EXPLORER

PROMAX launches its new HDTV instrument. This new jewel from the **PROMAX** factory will become a reference in the industry for being the very first meter of its kind to actually meet the requirements to be called a "real" HDTV instrument.

15.4" High Definition Display

16:9 Format

1080i 720p

SAT
DVB-S/S2

CABLE
DVB-C

TERRESTRIAL
DVB-T/H



Touch Screen

Audio Video output

- CAM Module
- SD Card
- RJ-45 Ethernet
- USB
- S/PDIF out
- SCART

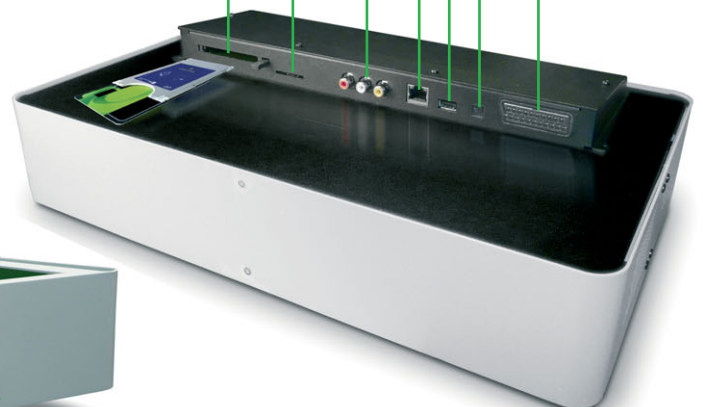

ASI in / out

RF Input

HDMI Connection



TV EXPLORER II+ Setting new standards

Since its launch, the **TV EXPLORER** has become the industry's standard instrument. It combines very reduced dimensions with an impressive data processing capacity, making measurements in a way that are most transparent to the user.



Explorer



The **TV EXPLORER** makes a dynamic exploration of the spectrum, detecting all the channels in the swept band and identifying all its parameters to lock the signal.

This new measurement concept sets a **radical change** in the way to understand and to use the meter. The analyser is no longer a passive unit, that only measures the channels. It is the analyser on its own that begins by locating all the channels available in the band.

Automatic advanced functions

The **TV EXPLORER** has set new standards in the way installers make and understand measurements. It includes an impressive new range of functions developed to easy measurements and to detect impairments in both digital and analog systems.

When pressing the “**explorer**” key briefly, it identifies the signal under test. First it recognises whether the channel is analog or digital.

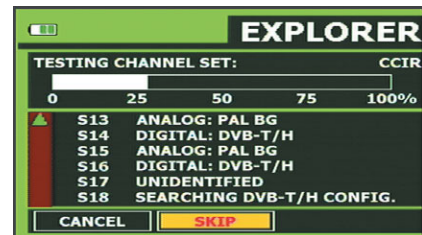

If the channel is analog, it determines the television standard of the signal (PAL/SECAM/NTSC).

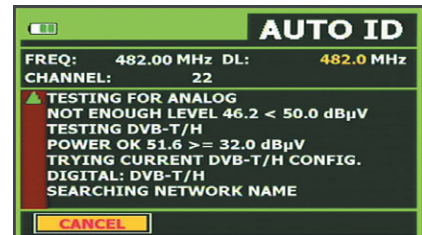

When the signal is digital, it analyses the modulation type: **QAM / QPSK / 8PSK / COFDM** (European Zone models) and all the associated parameters such as the system, the symbol rate, the code rate, etc and it tries to lock the signal.

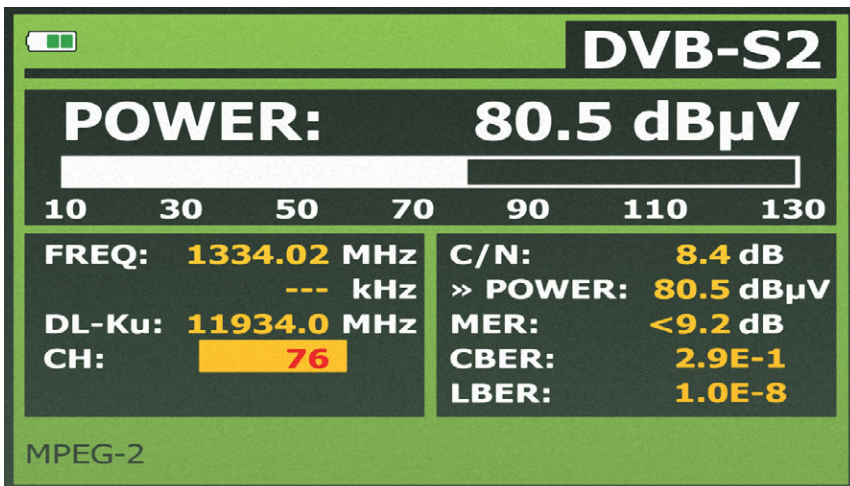

Merogram: MER by carrier as a function of time

The Merogram is a useful function designed to help in the detection of DVB-T or DVB-H channel reception problems.

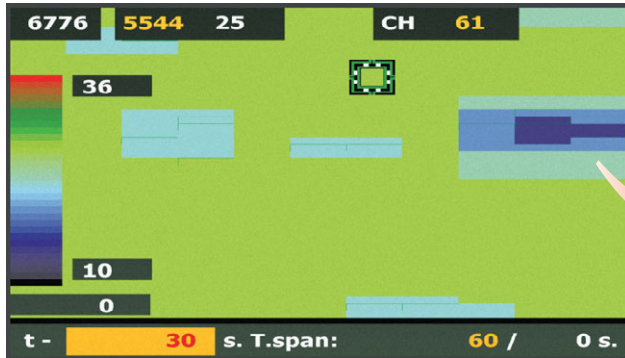

Example of Merogram

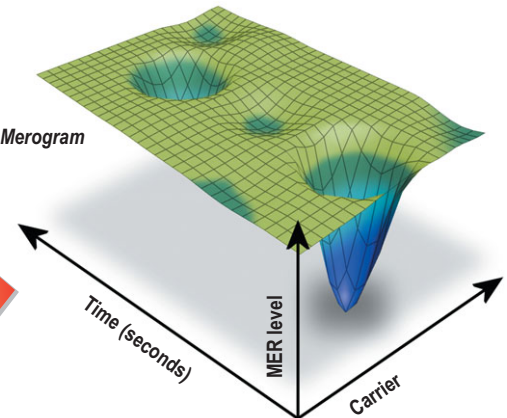

It has been developed to allow for an early identification of intermittent and sporadic problems that may happen in limited periods of time.

The Merogram function shows in a graphical form the values of MER by carrier as a function of time. MER values are represented in a colour scale. The vertical scale shows the

different individual carriers that form the COFDM multiplex while the horizontal scale is the time.

The result is a colour map like that one shown on the picture. There is a cursor that can be moved around the graphic to display the actual MER values and time stamps of the selected area.

Colour spots on the graphic mean signal reception problems that may have affected only part of the multiplex or occurred during a fraction of time to disappear afterwards thus making them impossible to find using other classic functions.

This function is only available for DVB-T and DVB-H channels.

Spectrogram: Spectrum display as a function of time

The Spectrogram function, similarly to Merogram, has been designed to detect problems that affect spectrum analyser display only in the form of unpredictable random bursts.

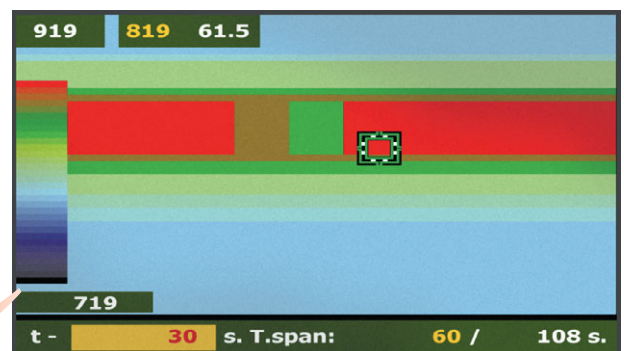
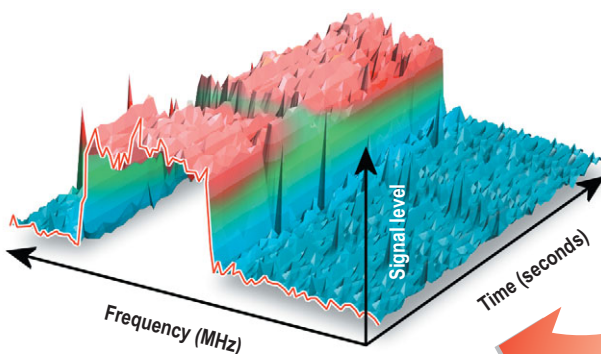

Example of Spectrogram

The Spectrogram is a graphic that shows time in the horizontal scale and the measured frequency span on the vertical scale. Signal levels are then represented by colours.

Colour spots on the graphic mean substantial signal reception variations that may be difficult to read otherwise. The Spectrogram function, unlike Merogram, can be used for all sorts of

signals within the frequency range of the **TV EXPLORER III+** not being limited by their modulation scheme.

The “ECHOES” on the DTT reception

During DTT broadcasting some echoes may appear due to the signal reflections on big objects such as buildings, mountains etc. With the **TV EXPLORER II / II+** is now possible to visualize the echoes.

Trying to overcome this inconvenience, the DVB-T standard defines the “Guard interval”, in this way the receptor does not take into account the replicated signal received during this period of time.

The user fixes the **Guard Interval** depending on the broadcasting characteristics and the geographical area where it takes place.

For that reason, those echoes that are predicted, when the delay is lower than the Guard interval, do not significantly affect the reception signal quality.

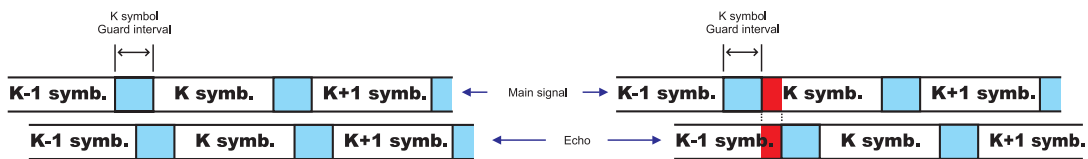
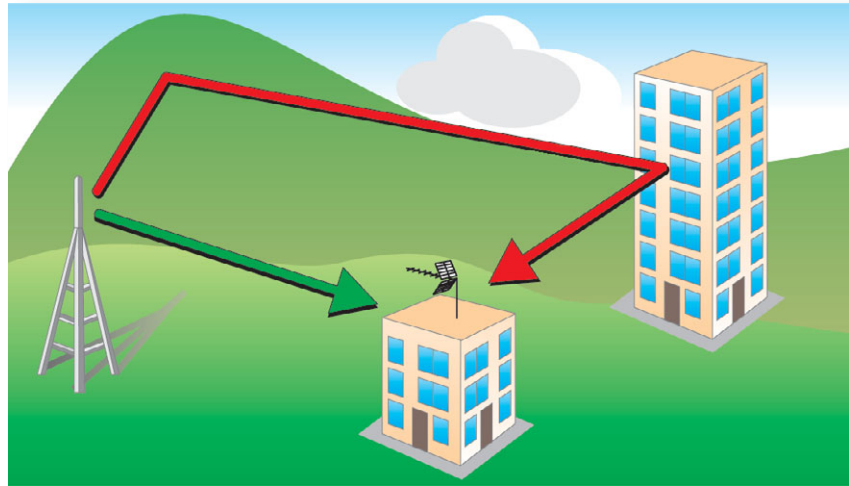

Echo with a delay lower than the Guard interval.
The echo with K-1 symbol does not jam the K symbol reception.

Echo with a delay higher than the Guard interval.
The echo with K-1 symbol jams the K symbol reception.

The echoes that are received out of the Guard interval affect the quality of the received signal and in a lot of cases the reception will be impossible. It depends on the delay and the amplitude of the echoes.

This situation may occur both in MFN (*Multiple Frequency Networks*) and SFN (*Single Frequency Networks*).

The first case, MFN, the echoes come from the reflections of the original signal, whereas in SFN echoes can also appear that come from other broadcasts, maybe far away from the original but at the same frequency.

Trying to reduce as much as possible all the echoes effects, the installer should also try to reposition the

receptor antenna according to the direction of the main emitter and try to reduce the others echoes received by the secondary lobes.

To make easy this task the TV EXPLORER II / II+ includes now the echoes function. For **TV EXPLORER II+** users, this function can be easily updated using the NetUpdate software.

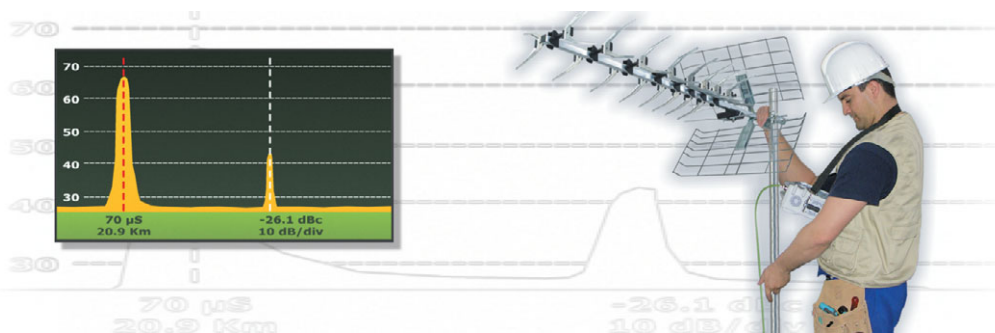

NetUpdate: Much more than just updating firmware

Updating the firmware of your analyser had never been as simple as with the **NetUpdate**.

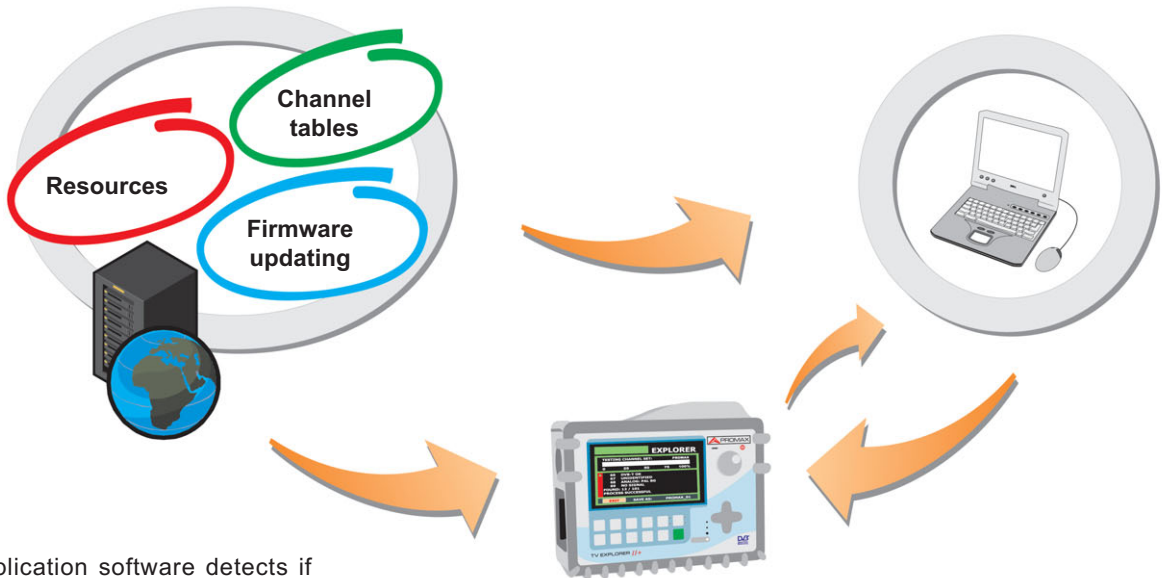

This application software detects if there is a new firmware version for the specific instruments that have been connected to the computer. If this is the case, it suggests the installation and it begins an **automatic update process**. This software is freeware and available at the **PROMAX** site.

Resources update

New **resources** for the **TV EXPLORER** are made available in the **PROMAX** server from time to time. The satellite channel tables for all satellites are included among these resources.

Data transfer and backup

The NetUpdate can also be used to make to transfer dataloggers, captured screens, video etc. and to **make backups** of the **TV EXPLORER** resources. The memory contents can be downloaded to the computer using the "drag-and-drop" technique:

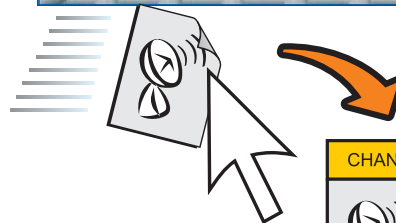
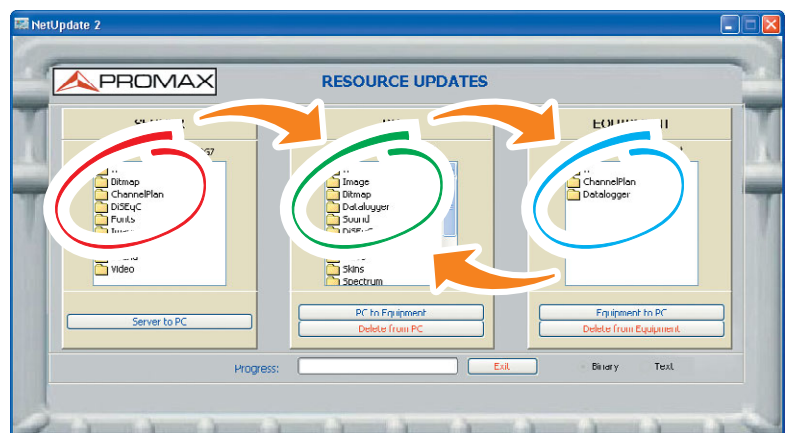

CHANNEL TABLE	
	19E2_ASTR_01
	70E5_EUTLW5
	42E_TURKSAT
	36E_EUROBIRD
	19E2_ASTR
	13E_HOTBIRD
	05E_SIRIUS

- ✚ Dataloggers
- ✚ Screen captures
- ✚ Video streams
- ✚ Standard or tailor made channel plans
- ✚ Other resources

SATHUNTER: including DVB-S2 for HD channels

The SATHUNTER is an instrument designed for the installation of Direct To Home (DVB-S/S2) satellite reception systems. It is fully automatic and very easy to use. Just turn the dish and the instrument will show up the identification of the selected satellite when it is detected. The instrument is actually reading the information transmitted by the satellite and displays its orbital position and the service list.



Easy to use

1.-Detection

It detects signal from any analogue or digital satellite thanks to the built-in wide band detector. In this mode the meter behaves like a satfinder and shows information about the received signal power in the form of two graphic bars with two different time constants and an audible indicator.

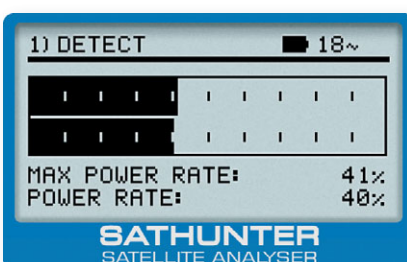

2.- Identification

Once a satellite signal has been found it is possible to confirm with no possibility of error if the received satellite corresponds to the one desired. To do that the SATHUNTER reads information from the transport stream tables at the preprogrammed test frequencies.

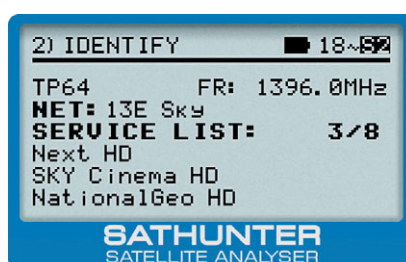

3.- Adjustment

It allows to make proper digital measurements such as channel power, MER or CBER. All information is displayed on the screen in a very convenient way so that optimising dish alignment becomes really easy. MER and CBER in particular are shown in numbers and a graphic bar as well.

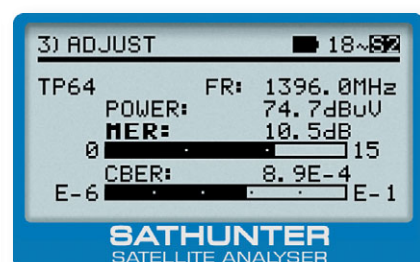

SATHUNTER: includes HD DVB-S2

Selective identification

The equipment can be programmed for a specific application, dish alignment for a specific satellite for instance. This could be the case of installers working for a particular DTH platform that want to eliminate any possibility of error and the related waste of time. Equipment settings can be modified at will using a PC computer and the supplied software.

Identification of up to 16 satellites

In **IDENTIFICATION (2)** mode, the equipment reads the information it receives from the satellite, presenting the orbital position and name of the service or satellite for a maximum of 16 satellites that can be programmed as the user deems appropriate.

Detection of short circuits and protection

The equipment allows detection of excessive LNB consumption. Outages in the cable or faulty LNB operation will be indicated by the equipment. It also has a short circuit detection feature.

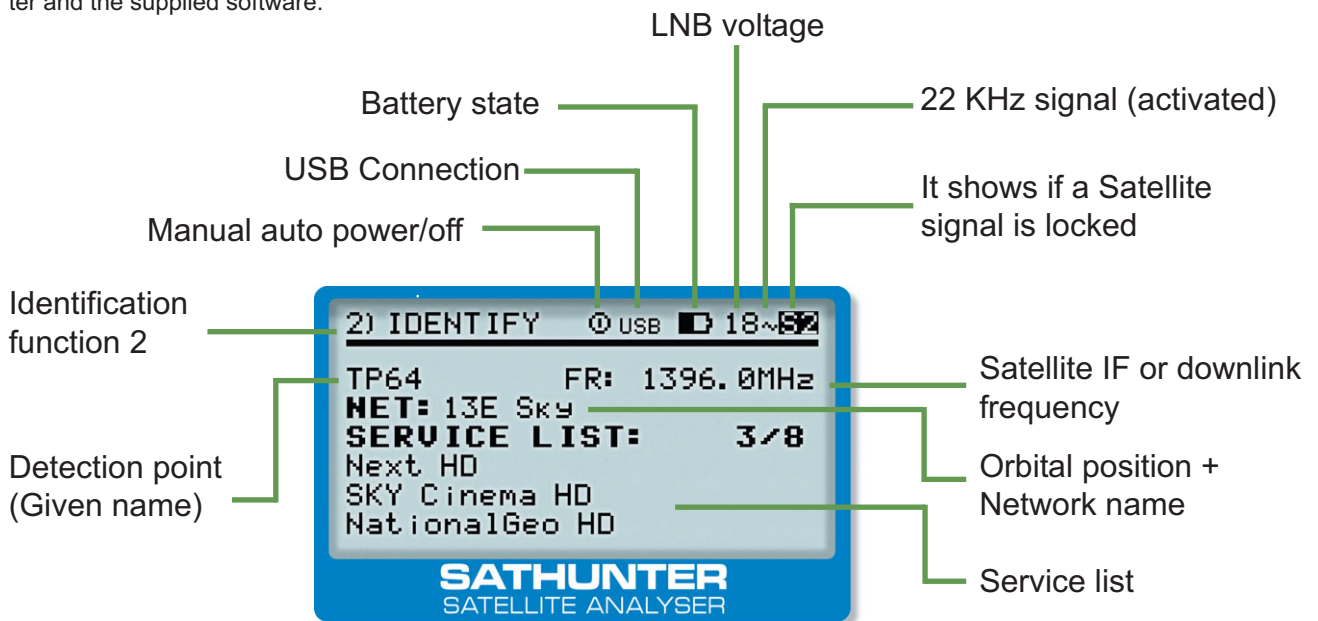

Long-life battery (Li-Ion)

Given the high consumption of LNBs, one of the fundamental features for this type of portable instrument is battery operating time. The **SATHUNTER** has been designed to allow continuous supply to universal LNB for over two hours. Battery charging time is about 2 hours but

70% of the total battery capacity is recovered in the first hour thanks to Li+ technology. Using the adapter cable shipped with **SATHUNTER**, the equipment can be charged from a vehicle's cigarette lighter in route to jobs. A universal charger is also delivered with the equipment.



Rough Construction

All details have been taken into account in the design of the **SATHUNTER**. It is a portable meter for outdoor use with a water resistant front panel and a sturdy ABS case. It uses a very comfortable replaceable RF input connector. The instrument comes with a hard transport case.



DIGITAL TO TV: Digital from satellite to TV

New TV distribution system that can deliver satellite TV channels in DTT.

Analogue TV distribution: Poor quality and low capacity

Very often TV picture quality in hotel rooms and cruise ship cabins is far from perfect. There are a number of factors that contribute to produce this poor performance but we can sum them up as the vulnerability of analogue television signals to noise, intermodulation, ghost image, etc.

The total investment required to build a large TV distribution system in a hotel, ship or convention centre can be huge. Any such system will require a headend, kilometers

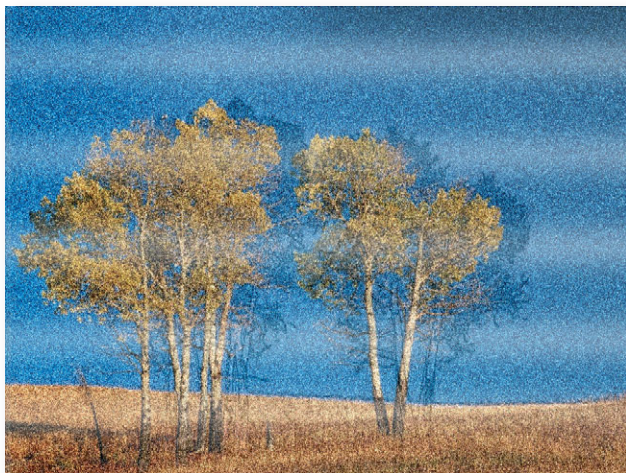

of cables, hundreds of splitters and connectors and hundreds of the latest technology flat screens!!!

Digital TV distribution: High quality and more channels

These days most televisions have made the final step towards digital and they are only being built with integrated digital receivers, iDTV.

Any impairment present in the analogue signal can be seen at once in a TFT or plasma TV, it no longer makes sense to distribute analogue TV signals to these state of the art receivers!

Installing a **PROMAX DIGITAL TO TV** solution offers superior video and audio quality delivering satellite digital

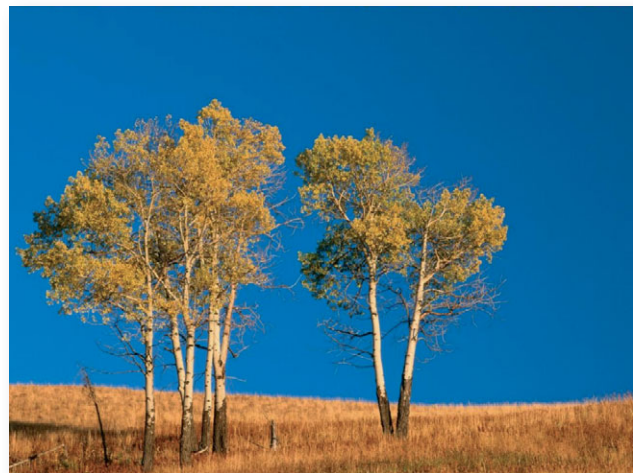

TV in DTT format. Customers will notice the difference and all that with a reasonable investment. Isn't it worth the change?

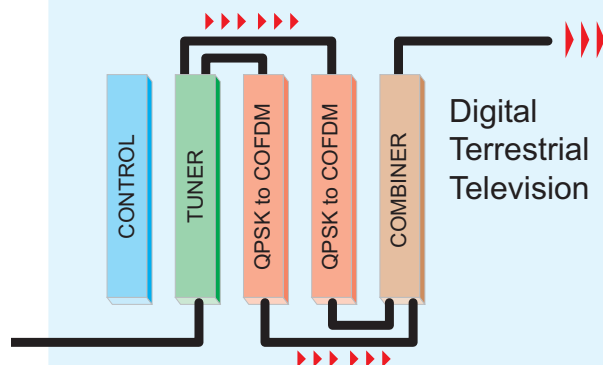

DIGITAL TO TV: Digital from satellite to TV

DIGITAL TO TV system advantages

Quality. 100% of the original quality is preserved. The Digital signal does not degrade as easy as the analogue one as it travels through the distribution system.

Efficiency. The possibility to deliver multiple programs per channel frees a lot of spectrum space.

Compatibility. There are many applications where using the existing RF wiring continues to be possible.

Convenience. Users need only a single remote control if the television set has DTT receiver built-in.

Scalable. It allows for the distribution of multiple satellite signals with no need for multiple receivers.

Tailorable. The DTT channels generated by the system can be placed anywhere in the spectrum so that they can be combined with other existing DTT channels coming from the aerial.

Encrypted channels. The receiver module includes a CAM interface to decode encrypted channels.

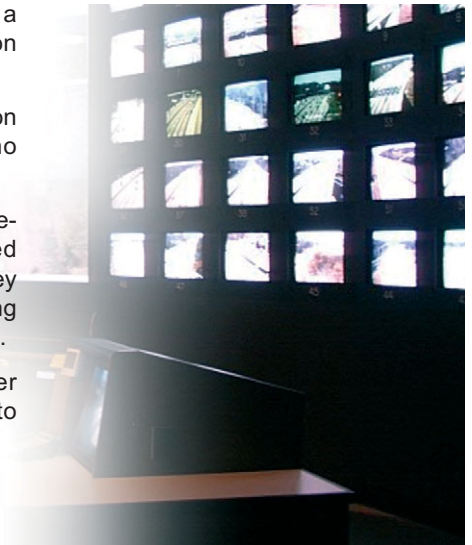

Dual DVB-S/S2 receiver

- This module contains two independent DVB-S/S2 receivers, each of them with 1 RF input and 2 identical ASI TS outputs.

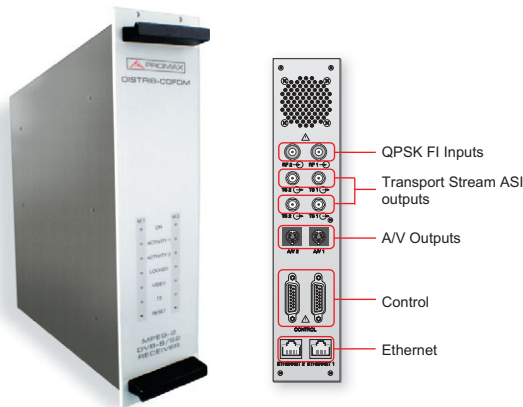

Dual DVB-T modulator

- This module contains two independent DVB-T modulators, each of them with an ASI TS input and a single common RF output.

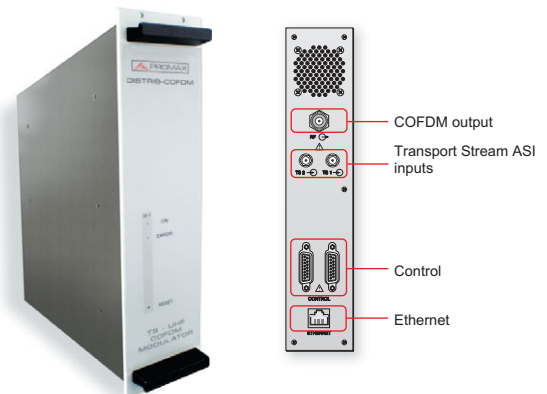

Combiner and splitter module

- Passive module that functions as a combiner (4 inputs, 1 output) and splitter (1 input, 4 outputs)

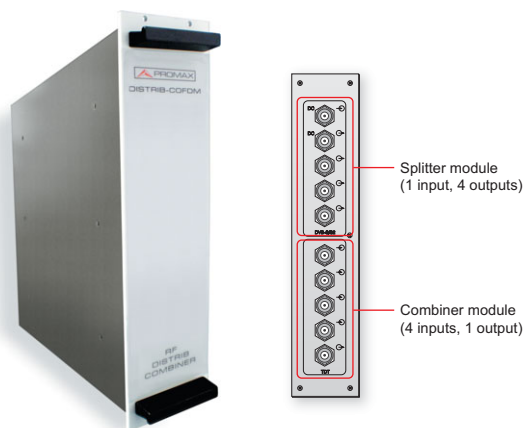

Control module

- It controls and supplies power to all the modules installed in the system in a centralised way. It also monitors that all modules are working properly



COFDM Transmodulators QPSK to COFDM MO-162 / MO-163

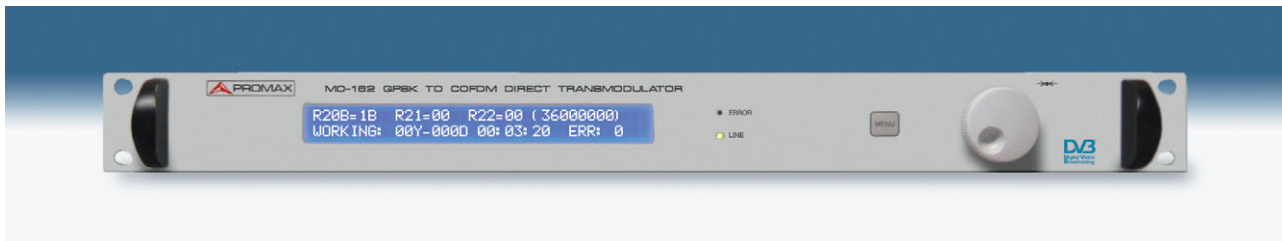

The **MO-162 / MO-163** are direct **QPSK to COFDM transmodulators**. They convert a satellite transponder into a Digital Terrestrial Television channel.

MO-162 / MO-163 allow to the selection of the satellite transponder at the input and the output channel for the resulting multiplex. Obviously, it must be taken into consideration that the transport capacity of a DTT multiplex is lower than that of a satellite transponder. Therefore, not all the services of a satellite transponder can fit into a

single multiplex. For that reason the **MO-162 / MO-163** allow for the selection of the services to be transferred.

The equipment is made on a unit chassis for assembly in a 19" rack. It has one F type IF satellite input (950 MHz to 2150 MHz).

The output coverage ranges from 475 MHz to 875 MHz for **MO-162** and 45 to 875 MHz for **MO-163** in 1 MHz steps. The output level can be adjusted in 1 dB steps and the MER is higher than 35 dB in all the channels.

The COFDM modulation modes can be set to 2 k or 8 k carriers.

The **MO-162 / MO-163** are ideal for use in Terrestrial Digital Television distribution systems at hotels, hospitals and in general in any cable distribution system.

The control of the operation of the **MO-162 / MO-163** is been made very easy through an LCD on the frontal panel. All the functions of the transmodulator can be easily selected by means of an intuitive set of menus.

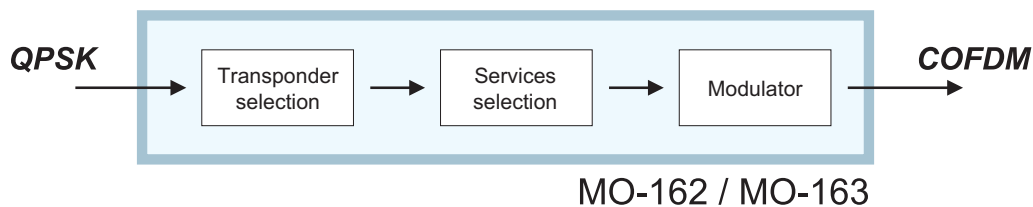

In this sample case, we use one **MO-162 / MO-163** to select up to four services from a **QPSK transponder** and pack them in a **COFDM multiplex**.

The **MO-162 / MO-163** allow the **selection of any of the transponders** at the input.

The next step will be to **select the services** that we wish to insert in the resulting multiplex.

Finally, we can **select the output channel** or frequency for this resulting multiplex.

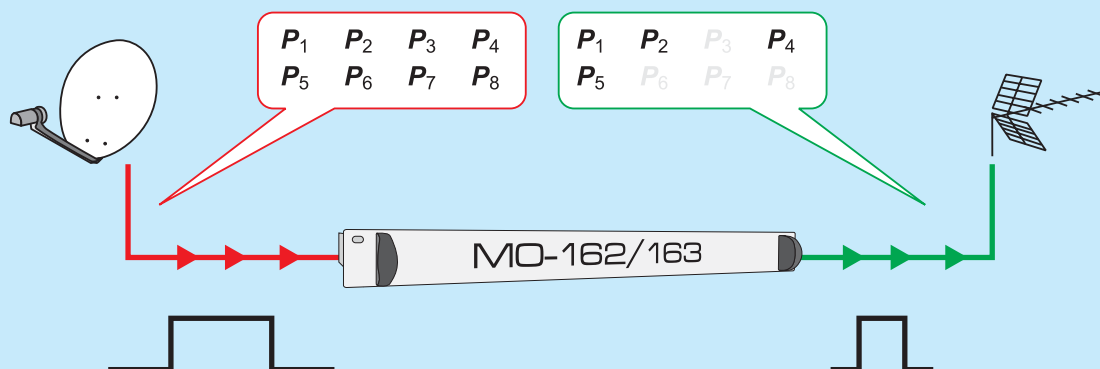

COFDM Modulators DVB-T/H MO-160/ MO-161



- **ASI and SPI inputs**
- **2 and 8 k modes**
- **Coverage: 475 - 875 MHz MO-160
45 - 875 MHz MO-161**
- **Frequency agility (1 Hz steps)**
- **High MER (> 35 dB)**
- **6, 7 & 8 MHz channel bandwidths (user-selectable)**



The **MO-160 / 161** is a general purpose **DVB-T modulator** contained in a 1U 19" chassis. The unit has one ASI MPEG-2 Transport Stream input.

The **MO-160 / 161** is able to work with any incoming bit rate as long as this is strictly lower than the value given in the DVB-T specification for the modulation parameters in use. The input TS bit rate is adapted to the useful bit rate required by the DVB-T signal by

stuffing the TS with NULL packets (packet stuffing). This stuffing process alters the sequence of PCR values embedded in the TS. These values have to be re-stamped for the resultant PCR jitter to remain within the limits specified by the DVB.

The modulator can be configured to generate any of the transmission modes listed in the DVB-T specification.

The channel bandwidth can be set by the user to 6, 7 or 8 MHz as required by the application.

The operation of the **MO-160 / 161** is done via the front panel LCD display and controls. The modulator can be easily configured by navigating through the intuitive set of menus.

Portable DTT Receiver and TS Recorder / Processor / Player TG-130

The **TG-130** is a versatile **MPEG-2 Transport Stream processor, recorder and player** with an integrated DVB-T tuner that allows TS capturing in real time.

Efficient and portable

The **TG-130** is a portable TS (Transport stream) recorder and player developed to help to identify problems related to digital television broadcast with a special focus in DVB-T or DVB-H.

It can record a TS continuously during several minutes so that it can be played back later on. The fragments recorded can also be splitted or combined with others to create new TS's. Errors such as NIT repetition period or wrong or missing data in some TS tables can be easily found using **TG-130**.



Application example

The **TG-130** is a field instrument, ideal for the capture of real DVB-T signals. It is compact, light and it has Lithium-Ion built-in batteries.

There are situations where a TV multiplex can be received in good conditions with high enough channel power and quality. This can also be confirmed using a TV **EXPLORER** for instance to measure MER, CBER and VBER.

But there are still other factors in digital TV broadcast that can yield to problems in some receivers to display the programs delivered in a specific multiplex. Not all receivers in the market respond in the same way to impairments in the TS tables for example. This happens too often nowadays while broadcasters begin their migration to digital transmissions.

Thanks to the **PROMAX TG-130** those type of problems can be identified fast and easy.

Portable DTT Receiver and TS Recorder / Processor / Player TG-130

The Transport Streams can contain a single service or multiple ones so that the user can have full flexibility during the test phases of digital set top box or iDTV's design, manufacture or service.

Services included in the transport stream can be audio, video or data in **MPEG-2** formats and can correspond to **free to air** or **encrypted** programs in standard definition (**SDTV**) or high definition (**HDTV**).

The **TG-130** comes with preloaded test transport streams that can be selected using the device front panel controls. Thanks to the PC computer



interface and the web server functions the users can also edit or tailor the transport streams to their specific requirements. The **TG-130** in combination with a digital modulator, such as **MO-170** for DVB-T for instance, becomes a highly flexible and affordable digital broadcast signal simulator.

The **TG-130** contains software programs to play, record, analyze, demultiplex and build Transport Streams.



The equipment has two outputs and one input: one ASI output (Asynchronous Serial Interface), one SPI output (Synchronous Parallel Interface) and one ASI input. It also has a RF input (from 35 to 100 dBμV).

The same data are sent to both outputs at the same time. The ASI uses a BNC type connector while the SPI uses a DB25.

The **TG-130** Data Compact Flash is recommended for applications like captures in the field where the equipment could be subject to knocks or vibrations. As it has no mechanical moving parts, it offers an improved longer term reliability.

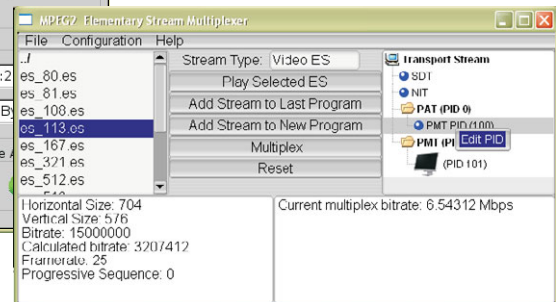
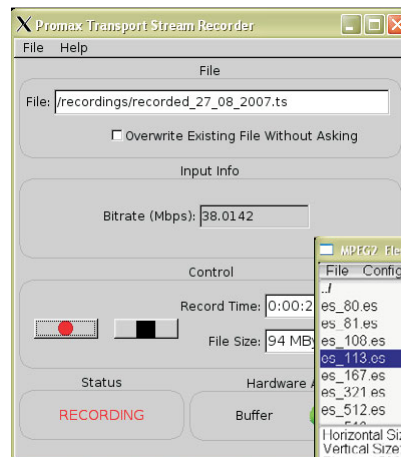

Example of a MPEG-4 pre-recorded test program

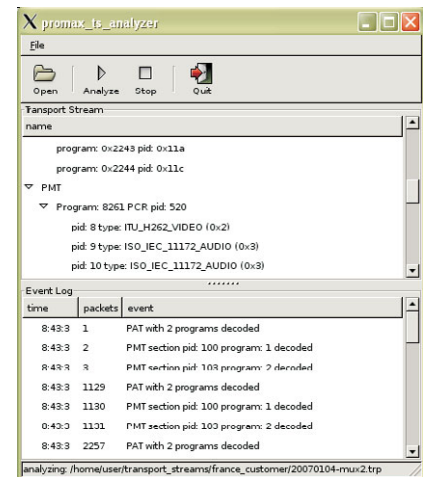

Remote Control

The **TG-130** can be easily operated using the rotary knob, keys and display available on the front panel. It is also possible to control the **TG-130** from a PC computer using the built-in ethernet interface. This Transport Stream recorder and player can also be connected to a computer network. Access controlled by password is available in this case for security purposes.

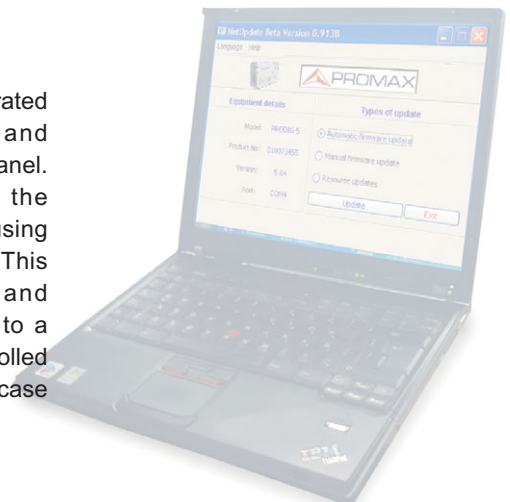

Monitoring Systems: PROWATCH TELMO

The **PROWATCH TELMO** is a remote monitoring system intended to analyse digital TV (DTT) signal quality at the transmitter location. It can be programmed to generate alarms if the measurements results are out of a given range.



The **PROWATCH TELMO** is composed of a compact module powered at 48 V which is easy to integrate in the existing infrastructure of any transmitter, repeater or gap-filler. The **PROWATCH TELMO** is available both in rack for mat as well as in a compact box for wall mount on DIN rail.

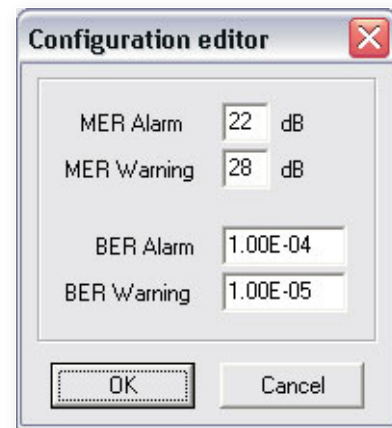

The **PROWATCH** product family is made of various models that can be tailored to meet specific customer monitoring requirements. The **TELMO** is a product that can be embedded inside the transmitter system.

These products have a focus on remote measurements and surveillance turn key solutions for digital and analogue television and radio signals.

Since **PROMAX** launched the **PROWATCH DEIDE** we had a growing presence in the market of remote monitoring systems with a product range designed to satisfy our customer's requirements in connection with TV and radio broadcast.

The **PROWATCH TELMO** basic system has been created for remote measurements of Digital Terrestrial TV (DTT) signals. It is installed at the transmitter location to monitor the quality of this type of signals. It generates alarms based on the different types of impairments detected.

From an electronic point of view, the unit is based on the most advanced circuits for DTT signal tuning, demodulation and measurement. Such design guarantees processing speed, stability and measurement reliability.

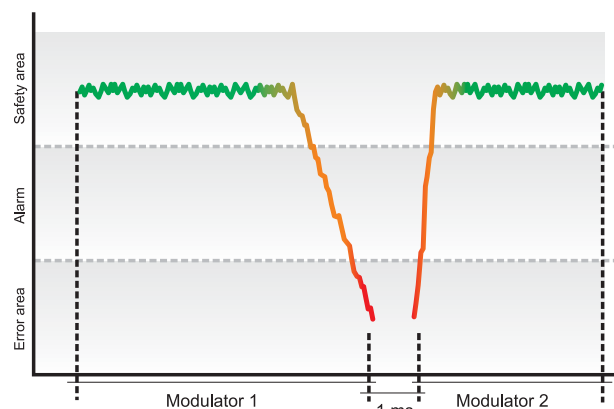
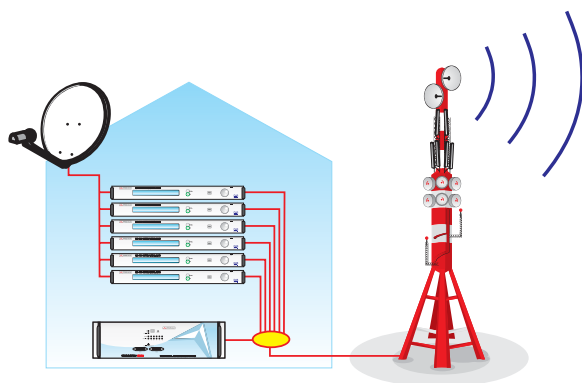

ERROR:
 ▲ The system switches the signal
 ▲ from Modulator 1 to Modulator 2 ▲

Monitoring Systems: PROWATCH TELMO



SNMP

The unit, once it has been configured, works as an autonomous element. Configuration can be modified by remote control making it not necessary to install a permanent user interface (display, keyboard...)

PROWATCH TELMO includes a serial port for data transmission to the remote monitoring location. A simple protocol is used to obtain information on system status, alarms generated or configuration data.

PROWATCH TELMO can monitor up to 6 digital TV multiplexes and generate WARNINGS or ALARMS depending on signal level, VBER or MER readings. It also has two DB25 connectors with internal 70 VDC relays that can be programmed for instance to

switch a faulty modulator in the transmitter to a back up unit.

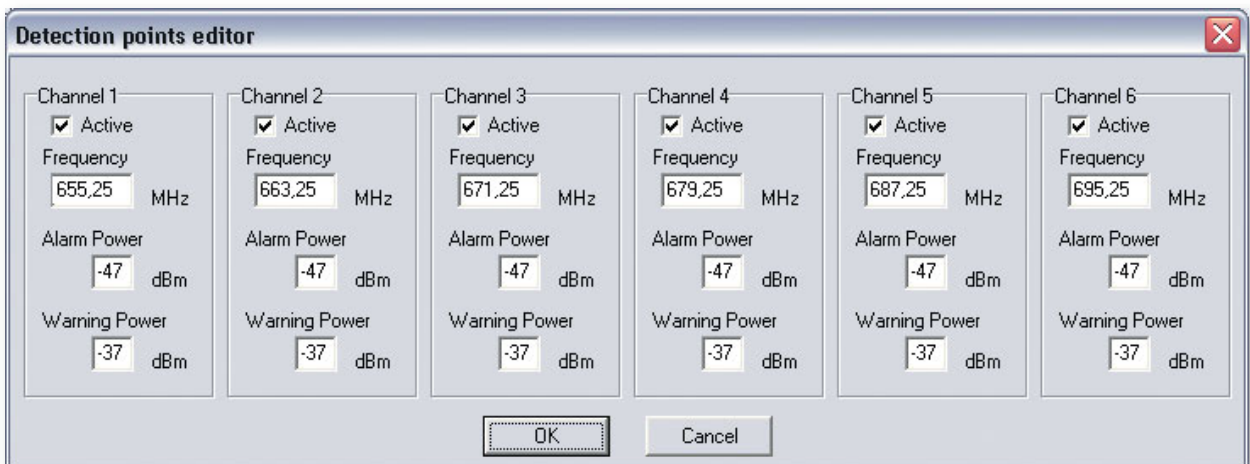

Cable TV & data analyser PROMAX-26+

PROMAX-26+ is an analyser for the installation, configuration and maintenance of video and high speed data interactive services over TV networks based on the EuroDOCSIS and DOCSIS 2.0 standard. It allows the qualification of VoIP services.



Upstream and Downstream

The **PROMAX-26+** communicates with the CMTS and shows the most important information related to the transmission: frequencies assigned in the upstream and downstream, signal quality in the downstream (power, BER, MER), power transmitted by the modem and attenuation in the return band.

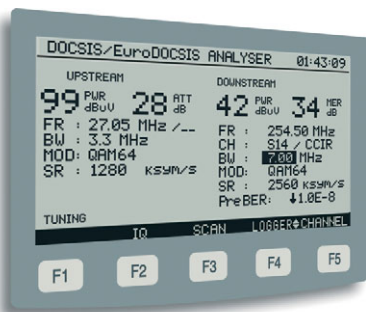

The upstream attenuation is a very important parameter and the installer must verify if this parameter is within the specified range.

MER and Constellation

These measurements are decisive for the early detection of excessive noise in the system or intermodulation problems in the downstream.

In general, a lower MER can mean system operating problems, as well as a slow speed due to the packets loss and interruptions.

The display of the constellation diagram and the bit error rate (BER) are other key measurements to evaluate the performance of the downstream.

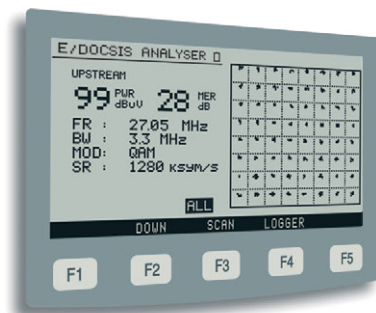

SCAN and level measurement function

The instrument also can be used to measure the RF level of analogue and digital signals. The signal level measurement can help us to determine if the system does not work right

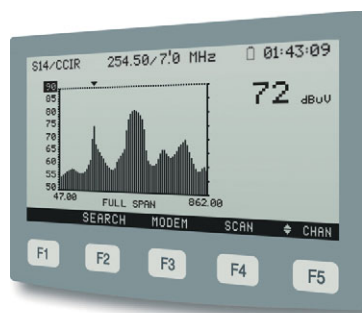

in order to allow the communication between the **PROMAX-26+** and the CMTS.

The **PROMAX-26+** incorporates a powerful spectrum analyser, which allows the visualisation of the full frequency band (FULL SCAN) and the each tuned channel (ZOOM SCAN). That is useful to analyse with detail any co-channel or adjacent channel interference.

Packet loss ratio

When the **PROMAX-26+** operates in registered mode, it can communicate in the network and can show useful data related to the IP addresses allocation and the form in which the packets flow throughout the network. The instrument calculates the ratio

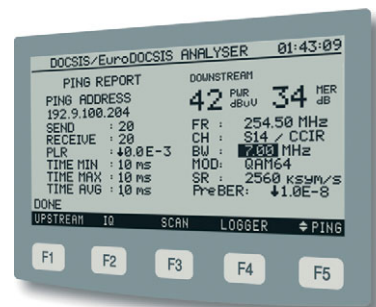

of packages received (PLR) which represents a statistical measurement about the traffic effectiveness through the network, as well as the maximum and minimum times for those receptions. This will allow to evaluate the network capability to support certain transport services (e.g. voice on IP) and to determine the global performance of the overall system.

Channel Searching

This function carries out an exploration of all **EURODOCSIS / DOCSIS** channels, collecting them in a list.

Cable TV & data analyser PROMAX-26+

For each channel it shows the power level received, the MER and the corresponding upstream channel identifier.

Channel Qualification

The **PROMAX-26+** includes a signal generator, a pilot signal with selectable level, frequency, modulation and symbol rate. It can be programmed to continuous or TDM mode in order to evaluate the quality of the upstream channel.

Datalogger mode

Most of the measurements both for the upstream and for the downstream (including IQ constellation) can be stored in the internal memory by means of the Datalogger function with up to 30 positions of capacity. All these data can be transferred to a personal computer (PC) to be processed later or to be included in the automated measurement reports.

Ethernet connection

The equipment offers the possibility to modify IP address, subnet mask and gateway settings to make Webserver available through the ethernet port.

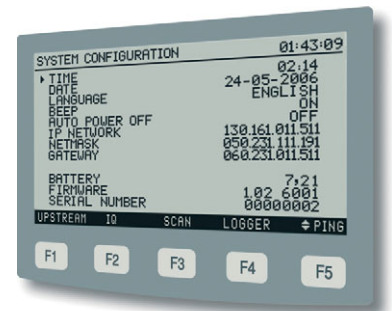

The **PROMAX-26+** is capable of the following measurements:

Downstream:

- Channel power
- MER, BER, Pre BER and Post BER
- Constellation diagram
- Full band power
- Frequency, channel and active channel plan
- Modulation type and symbol rate

Upstream:

- Power
- Attenuation at CMTS
- Frequency and bandwidth
- Modulation and symbol rate
- Communications test

Communications Test (in Registered mode):

- IP report
- Ping test
- Ratio of lost packets

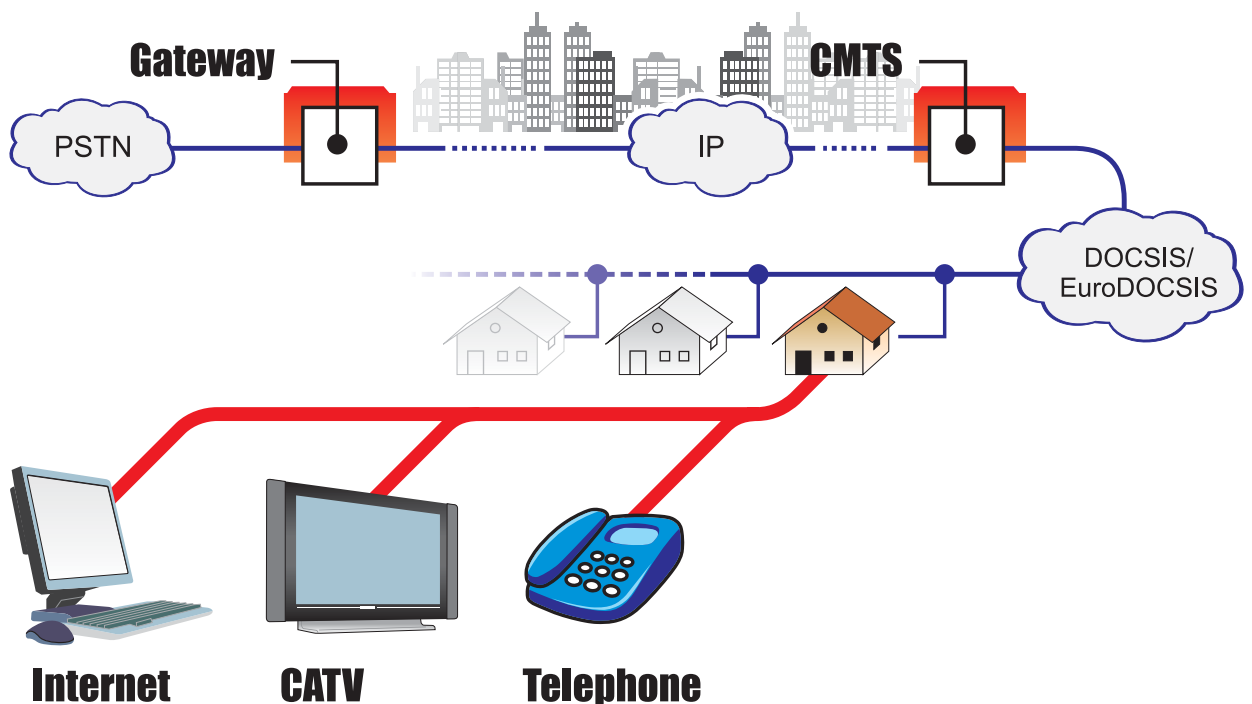

PROWATCH DEIDE 3 for Cable TV headends

We can now offer a version of the well known **PROWATCH DEIDE 3** specially tailored to the requirements of cable TV headend monitoring.



Typically a monitoring system in this application will require a number of RMU's (Remote monitoring units). Each of them will include built in http and snmp servers and they will normally be placed at the headends in this particular case.

QAM measurement capabilities have been added to the remote measuring units (RMU's) so that the system is compatible with both analogue and digital signals.

