

TABLE OF CONTENTS

1	GENERAL	1
1.1	Description	1
1.2	Specifications	1
2	SAFETY RULES	5
2.1	General	5
3	INSTALLATION	7
3.1	Power supply	7
3.1.1	Operation using the external DC adapter	7
3.1.2	Operation using the battery	7
3.1.3	Battery charging	8
3.2	Battery installation	8
3.3	Installation and start up	9
4	OPERATING INSTRUCTIONS	11
4.1	Description of the controls and components	11
4.2	Instrument configuration	12
4.2.1	Meter mode	14
4.2.2	Acquiring the reference power. (<i>Set Ref.Level</i>)	14
4.2.3	Selecting the wavelength state (<i>Set WaveLength</i>)	14
4.2.4	Selecting reading display	15
4.2.5	Speaker configuration (<i>Speaker</i>)	15
4.2.6	Display backlight (<i>BackLight</i>)	16
4.3	Taking readings	16
4.3.1	Measuring Absolute Power	16
4.3.2	Measuring Relative Power	17
5	MAINTENANCE	19
5.1	Cleaning Recomendations	19
5.2	Battery replacement	19

OPTICAL POWER METERS

PROLITE-20 and PROLITE-21

1 GENERAL

1.1 Description

The **PROLITE** series has been specifically designed for the *operation (start-up) and maintenance of optical fibre installations. This series consists of two light sources, the **PROLITE-80** and the **PROLITE-81**, and two optical power meters, the **PROLITE-20** and the **PROLITE-21**.

The **PROLITE-20** and the **PROLITE-21** are two portable, sturdy, low-weight optical power meters, tailor-made for hand-held work. These features make them ideal tools for field work.

The basic difference between the **PROLITE-20** and the **PROLITE-21** is their measuring range. Whereas the **PROLITE-20** measures power between - 50 dBm and + 25 dBm, for the different wavelengths available, the **PROLITE-21** can measure power between - 70 dBm and + 5 dBm

In both models, when the battery is flat, the low battery (LB) indicator on the screen flashes and, approximately every 2 s, whether it is activated or not, the speaker also emits a whistle.

1.2 Specifications

OPTICAL INPUT

Detector type	InGaAs
Wavelength range	820 nm to 1625 nm
Calibrated wavelengths	850 nm, 1300 nm, 1310 nm, 1550 nm
Input connector	Exchangeable (see accessories)
Maximum signal	
PROLITE 20	+ 27 dBm ¹
PROLITE 21	+ 10 dBm

¹ For 1300,1310 and 1550 nm

POWER METER**Meter range****PROLITE 20**- 50 dBm to + 25 dBm ¹**PROLITE 21**

- 70 dBm to + 5 dBm

Meter range selection

Automatic

Units:

dBm , dB

Resolution

0.01 dB

Accuracy ± 0.2 dB (5%) ²**Linearity** ± 0.05 dB ³**Temperature stability** ± 0.3 dB at 850 nm and ± 0.2 dB at 1550 nm**Display**

16-digit, alphanumeric LCD with backlight.

Reading**Numeric**

dBm in absolute power mode and dB in relative power mode.

Graphic

Bar graph.

PROLITE 20

from - 40 dBm to + 25 dBm

PROLITE 21

from - 60 dBm to + 5 dBm

Fibre modes

MM and SM

Tone detector270 Hz, 1 kHz and 2 kHz ($\pm 1\%$) acoustic**PROLITE 20**

from - 30 dBm to + 25 dBm

PROLITE 21

from - 50 dBm to + 5 dBm

POWER SUPPLY**Battery**

7.2 V, 950 mAh, Ni-Cd battery

Low battery indication

LB flashes at the far right of the display.

Autonomy

Typically 30 h, without a backlit display

Charging time

14 hours with a completely flat battery.

Battery charger mains adapter

230 V/50-60 Hz/10 W (EUROPE and other countries)

Power consumption

1.5 W

OPERATING ENVIRONMENTAL CONDITIONS**Altitude**

Up to 2000 m

Temperature range**operating**

From 0 to +40 ° C

storage

From -10 to +60 ° C

Max. relative humidity

50 % to 30° C, 10 % to 40° C

¹ For 1300,1310 and 1550 nm² For 1308 nm and - 10 dBm, using 9/125 m fibre, at 23 \pm 1 °C, with a source whose spectrum-width is < 0.2 nm and an FC connector.³ From - 40 dBm to 0 dBm for the **PROLITE-20** and from - 60 dBm to 0 dBm for the **PROLITE-21**

MECHANICAL FEATURES

Dimensions 90 mm (W) x 218 mm (H) x 50 mm (D)
Weight 495 g

INCLUDED ACCESSORIES

1x AA-012 Car lighter adapter cable
1x AL-013 EUROPE and other countries 230 V / 50-60 Hz mains power adapter
1x AL-023 USA and CANADA 120 V / 50-60 H mains power adapter
(only with the OPT-01).
1x CB-038 Rechargeable battery 7.2 V, 950 mAh

OPTIONAL ACCESSORIES

1x AD-070 ST Connector
1x AD-071 E2000 Connector
1x AD-072 SC Connector
1x AD-073 FC Connector
1x AD-074 SMA Connector

2 SAFETY RULES



2.1 General

- * When using some of the following accessories **use only the specified ones** to ensure safety.

Rechargeable battery
External DC adapter

- * Observe all **specified ratings** both of supply and measurement.
- * Remember that voltages higher than **60 V DC** or **30 V AC rms** are dangerous.
- * Use this instrument under the **specified environmental conditions**.
- * **The user is only authorised to** carry out the following maintenance operations:

Battery replacement.

On the Maintenance paragraph the proper instructions are given.

Any other change on the equipment should be carried out by qualified personnel.

- * Follow the **cleaning instructions** described in the Maintenance paragraph.

* Symbols related with safety:



DIRECT CURRENT



ALTERNATING CURRENT



DIRECT AND ALTERNATING



GROUND TERMINAL



PROTECTIVE CONDUCTOR



FRAME TERMINAL



EQUIPOTENTIALITY



ON (Supply) / OFF (Supply)



DOUBLE INSULATION
(CLASS II protection)



CAUTION
(Risk of electric shock)



CAUTION (Refer to manual)



FUSE

3 INSTALLATION

3.1 Power supply

The **PROLITE-20/21** is a portable instrument powered by a 7.2 V, 950 mA/h, NiCd, rechargeable battery. The device is accompanied by an external DC adapter which enables the **PROLITE-20/21** to be connected to the mains for operation and battery charging.

3.1.1 Operation using the external DC adapter

The instrument comes with a 230 V / 50-60 Hz mains adapter, for EUROPE and other countries, for powering the **PROLITE-20/21**. (See accessories for ordering other types of adapters.)

Once the battery is installed in the instrument, connect the external DC adapter to the **PROLITE-20/21** using the external power connector [8] located on the left side. Connect the DC adapter to the mains, thereby starting the battery charging process. Next, press the start/stop button [4] on the **PROLITE-20/21**. Under these conditions, the instrument starts to function. Battery-charging time increases if the instrument is used during the process.

WARNING

Before connecting the mains adapter, make sure that it is the appropriate one for your mains system.

The mains adapter is designed for indoor use.

Never start the instrument with the external adapter connected if the battery is not in place.

3.1.2 Operation using the battery

For the instrument to work using the battery, you need only press the start/stop button [4]. With the battery fully charged and the display not illuminated, the **PROLITE-20/21** has an approximate autonomy of 30 hours uninterrupted operation.

When the battery is flat, you will see the low battery indicator on the screen and, afterwards, the instrument will automatically switch off.

3.1.3 Battery charging

To fully charge the battery with the **PROLITE-20/21** switched off, connect the external DC adapter to the power supply input [8]. Then connect the adapter to the mains. Charging time depends on the state of the battery. If the battery is very flat, charging will take some 14 hours.

3.2 Battery installation



Only use **CB-038** batteries.

To install the battery, place it on the base of the arrows at the rear of the instrument. Slide it in until you hear a "click" and the battery is secured, as shown in figure 1.

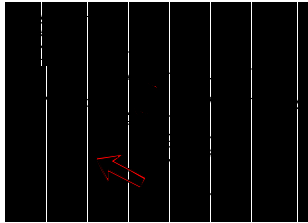

Figure 1.- Battery installation.

Battery removal

The battery is accessible from the rear of the instrument. To disconnect the battery, press the flange located at the bottom (1) and proceed to separate the battery from the instrument body (2). The battery will come away from its housing. Then slide it out, as shown in figure 2.

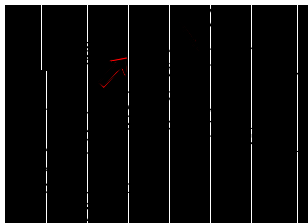

Figure 2.- Battery removal.

3.3 Installation and start up

The **PROLITE-20/21** has been designed for use as a portable instrument. When the battery is inserted in its housing and the instrument switched on, for a few seconds, the display will show the name of the instrument and the software version. E.g. in the case of the **PROLITE-21**:



Figure 3.-

A fully charged battery will power the instrument for some thirty hours if the display is not illuminated. The battery should be recharged when the low battery indicator (LB) appears on the display.

When installing a completely flat battery, you may find that the **PROLITE-20/21** starts up due to residual charges, however, the instrument will automatically disconnect before the low battery indicator appears on the display.

4 OPERATING INSTRUCTIONS

4.1 Description of the controls and components

Front panel

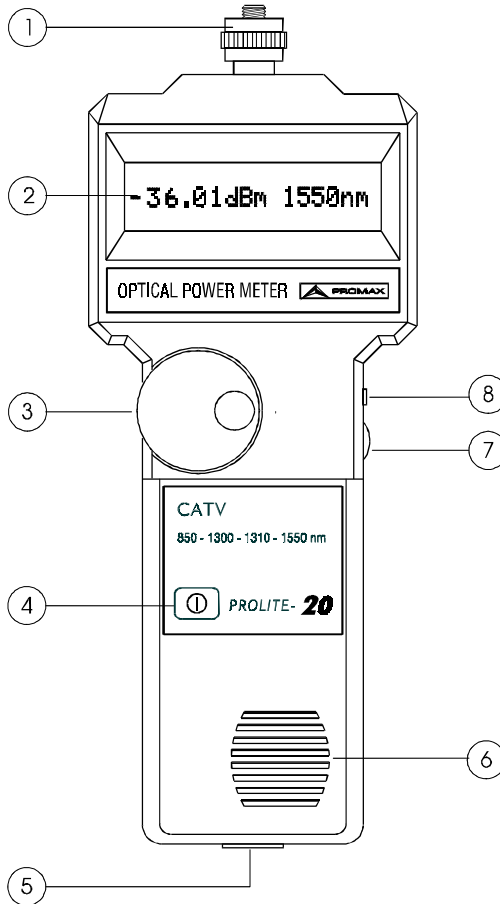

Figure 4.-Front View.

[1] Input connector



Maximum input level: + 27 dBm for the **PROLITE-20** y + 10 dBm for the **PROLITE-21**.

[2] Backlit alphanumeric display.

[3] Rotary selector. Used to access the configuration menu, change the states of the various parameters and select the different options.

[4] Star/stop key.

[5] Computer connection for calibration



Never connect any cable which has not been supplied by the manufacturer as it may seriously damage the instrument.

[6] Speaker

[7] Display contrast control

[8] Exterior power supply and charging input.

4.2 Instrument configuration

The configuration screen enables the following parameters to be modified:

- Selects the active meter mode as either Absolute (*Absolute Mode*) or Relative Power Meter Mode (*Relative Mode*).
- The reference value of the active wavelength in Relative Power Meter Mode (not available in Absolute Power Meter Mode). *Set Ref. Level*.
- Selects the state of the wavelength as either selective or non-selective: *Set Wavelength*.
- Selects how the reading is to be shown on the display, either *Numeric Level* or *Bar Graph Level*.
- Speaker activation/deactivation (*Speaker*).
- Backlight activation/deactivation (*BackLight*).

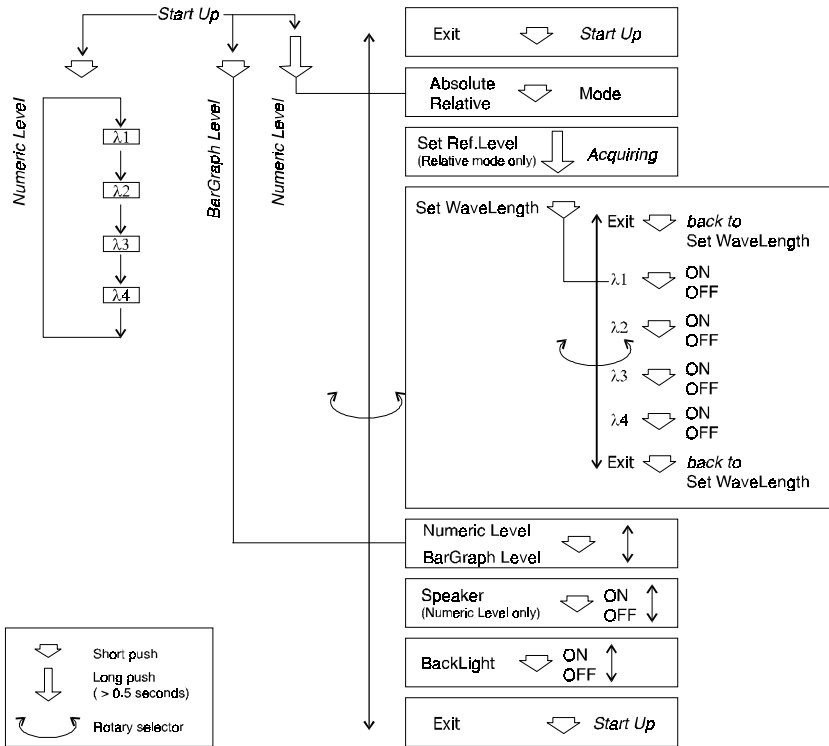

Figure 5.- Flow diagram

To access the **PROLITE-20/21** configuration menu when the instrument is on, keep the rotary selector pressed down a few seconds until the configuration menu appears (you will hear a second beep).

To leave the configuration screen, turn the rotary selector until *Exit* appears on the display, then confirm by pressing the selector. You will be taken back to the meter screen.

English

4.2.1 Meter mode

Press the rotary selector to select the desired meter mode. The configuration will change sequentially.

Absolute Mode Absolute Power Meter Mode .

Relative Mode Relative Power Meter Mode. The reference value is measured by selecting *Set Ref.Level*.

This option is not available in bar graph form.

4.2.2 Acquiring the reference power. (*Set Ref.Level*)

(Only available in Relative Power Meter Mode)

Enables the reference value for the active wavelength to be acquired, taken, simply by pressing the rotary selector.

To acquire the reference power, press the rotary selector when *Set Ref. Level* appears on the display, then keep it pressed down until the instrument finishes taking the reading and automatically leaves the configuration mode. During the acquisition process, the display will show (from left to right) a series of asterisks indicating how the acquisition is proceeding.

If you stop pressing the rotary selector during the measurement process, the process halts and the instrument continues to use the previous reference value.

4.2.3 Selecting the wavelength state (*Set WaveLength*)

Enables the state of the different wavelengths to be configured, helps determine if a specific wavelength can be selected by repeatedly pressing the rotary selector. This option is not available when using the bar graph.

When *Set WaveLength* appears on the display, confirm by pressing the rotary selector. The display will show the longitude of the first of the four available wavelengths (in nm) and its state (ON if it can be selected, OFF if not). The state may be modified by pressing the rotary selector. To alter the state of other wavelengths, turn the rotary selector until the desired wavelength appears on the display, then press the rotary selector to modify its state. Once you have completed the modifications you need, you can return to the main menu by turning the rotary selector until *Exit* appears on the display, then press the rotary selector to confirm.

4.2.4 Selecting reading display

Enables selecting between numeric reading display (*Numeric Level*) and bar graph display (*BarGraph Level*), when taking readings. Bar graph display is not available in Relative Power Meter Mode.

In bar graph mode, the instrument display shows a bar graph indicating the absolute power and, on the far right, the numeric figure corresponding to the absolute value without units.

To select the bar graph display, keep the rotary selector pressed down until the configuration menu appears on the display. Turn the rotary selector until you see *Numeric Level* (numeric display) and press the selector to change to bar level display (*BarGraph Level*). Leave the configuration menu by turning the rotary selector until *Exit* appears, then press the selector to confirm.

In bar graph display it is not possible to change the longitude of the active wavelength or the meter mode. Only the configuration menu options corresponding to the graphic display and the backlight can be changed. The configuration menu options available in this display mode can be easily accessed by pressing the rotary selector.

To return to numeric display, press the rotary selector to access the configuration menu. The screen will show *BarGraph Level*. Change to numeric display (*Numeric Level*) by pressing the selector and leave the configuration menu by turning the rotary selector until *Exit* appears, then press the selector to confirm.

4.2.5 Speaker configuration (*Speaker*)

(Only available in numeric display mode)

Enables speaker activation/deactivation (ON/OFF). The **PROLITE-20/21** automatically detects if the light striking the instrument is modulated by a 270 Hz, 1 kHz or 2 kHz signal. If it has been activated, the speaker emits a sound at the same frequency as the modulation (270 Hz, 1 kHz or 2 kHz).

To activate/deactivate the speaker, turn the rotary selector until you see *Speaker* on the display, then press the selector to change the configuration. The configuration will change sequentially.

4.2.6 Display backlight (*BackLight*)

Enables backlight activation/deactivation (ON/OFF). The possibility of illuminating the display enables you to comfortably work under poor lighting (night-time, badly lit locations, etc.) and, therefore, increases the number of situations where it is particularly useful.

To activate/deactivate the backlight, turn the rotary selector until you see *BackLight* on the display, then press the selector to change the configuration. The configuration will change sequentially.

The instrument enables the display backlight to be activated even when the battery is relatively flat and the low battery indicator appears on the display. In this case, you should be particularly aware that activating the display illumination decreases autonomy by consuming energy.

4.3 Taking readings

The PROLITE-20/21 has two meter modes: the Absolute Power Meter mode and the Relative Power Meter mode.

4.3.1 Measuring Absolute Power

In this meter mode the instrument measures absolute power (in dBm) at the selected wavelength.

To select this meter mode, access the configuration menu by keeping the rotary selector pressed down a few seconds (until you hear a second beep). You will then see the active meter mode: *Absolute Mode* in the case of Absolute Power Meter Mode or *Relative Mode* in the case of Relative Power Meter Mode. Select the absolute mode by pressing the rotary selector (*Absolute Mode* will appear on the display). Leave the configuration menu by turning the rotary selector until *Exit* appears, then press the selector to confirm.

The display will show the value corresponding to the measured power (in dBm) and the wavelength (in nm) at which it is being measured.

The wavelength at which the absolute power is measured can be selected from those available (ON state, see 4.2.3) by repeatedly pressing the rotary selector until it appears on the display.

4.3.2 Measuring Relative Power

In this meter mode the instrument measures relative power (in dB) at the selected wavelength.

The display will show the value corresponding to the difference between measured power and the reference power (in dB) and the wavelength at which it is being measured.

The wavelength at which you wish to measure the relative power can be selected from those available (ON state, see 4.2.3) by repeatedly pressing the rotary selector until it appears on the display.

Once you have selected the wavelength, access the configuration menu by pressing down the rotary selector a few seconds (until you hear a second beep). The active meter mode will then be shown: *Absolute Mode* in the case of Absolute Power Meter Mode or *Relative Mode* in the case of Relative Power Meter Mode. Select the relative mode by pressing the rotary selector (*Relative Mode* will appear on the display) and proceed to obtaining the reference power. To obtain it, turn the selector until you see *Set Ref.Level* on the display and keep pressed down until the instrument finishes data acquisition, automatically leaves the configuration menu and begins to measure using the new reference value. During the acquisition process, the display will show a series of asterisks appearing from left to right, indicating how the acquisition is proceeding.

If you stop pressing the rotary selector during the acquisition process, the process halts and the instrument continues to use the previous reference value.

The instrument stores a reference power for each available wavelength. In the case of no new reference power being measured, the value used by the instrument will correspond to the last reference power obtained.



5 MAINTENANCE

This part of the manual describes the maintenance procedures.

5.1 Cleaning Recommendations

CAUTION

To clean the cover, remove the battery from its housing.

CAUTION

Do not scented hydrocarbons or chlorized solvents. Such products may attack the plastics used in the constructions of the cover.

The cover should be cleaned by means of a light solution of detergent and water applied with a soft cloth. Dry thoroughly before using the system again.

CAUTION

The clean the contacts, use a dry cloth. Do not use a wet or damp cloth.

CAUTION

Do not use for the cleaning of the front panel and particularly the viewfinders, alcohol or its derivatives, these products can attack the mechanical properties of the materials and diminish their useful time of life.

5.2 Battery replacement

See paragraph 3.2.

